

NOTE:
Please read all
instructions carefully
before using this product

Table of Contents

Safety Notice

Hardware Identifier

Assembly Instruction

Parts List

Warranty

Ordering Parts

Model
MWB-5085

Retain This
Manual for
Reference

170630

OWNER'S
MANUAL

MARCY[®]

MARCY PRO WEIGHT BENCH

MWB-5085

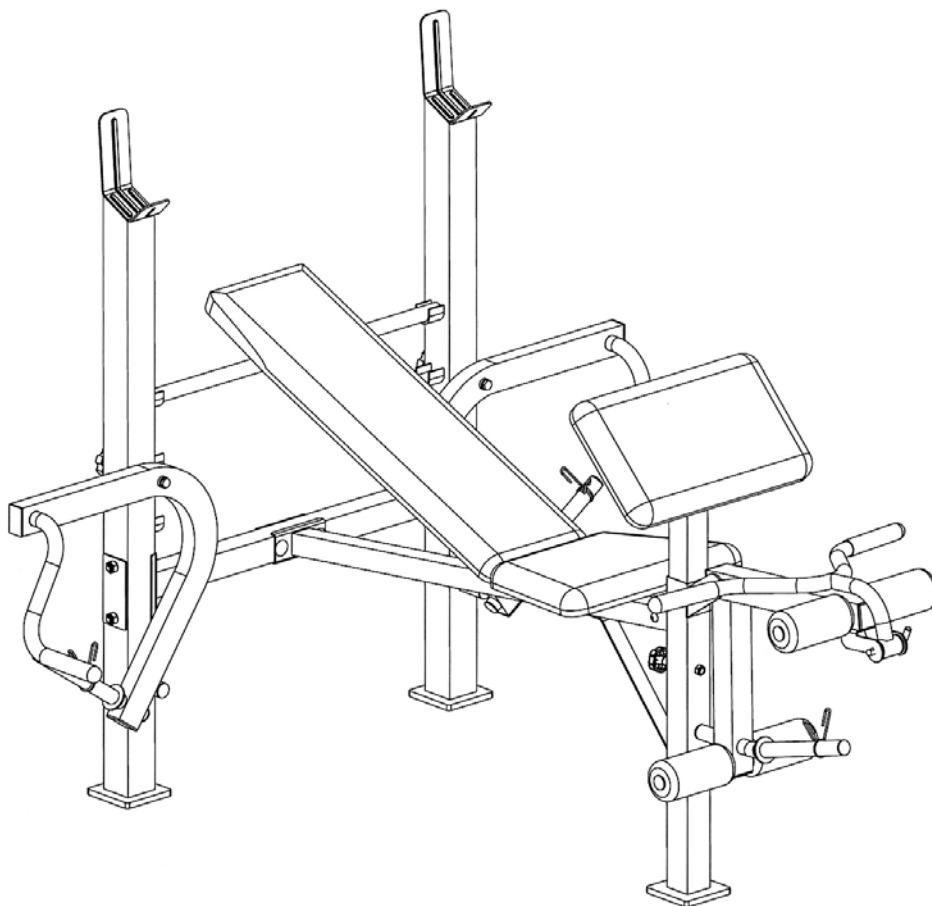

IMPEX[®] INC.

2801 S. Towne Ave., Pomona, CA 91766
Tel: (800) 999-8899 Fax: (626) 961-9966

www.marcypro.com

support@impex-fitness.com

TABLE OF CONTENTS

BEFORE YOU BEGIN.....	2
IMPORTANT SAFETY NOTICE.....	3
HARDWARE IDENTIFIER.....	5
ASSEMBLY INSTRUCTIONS.....	7
EXPLODED DIAGRAM.....	11
PARTS LIST.....	12
WARRANTY.....	13
ORDERING PARTS.....	13

BEFORE YOU BEGIN

Thank you for selecting the MARCY PRO Weight Bench MWB-5085 by IMPEX[®] INC. For your safety and benefit, read this manual carefully before using the machine. As a manufacturer, we are committed to provide you complete customer satisfaction. If you have any questions, or find there are missing or damaged parts, we guarantee you complete satisfaction through direct assistance from our factory. To avoid unnecessary delays, *please call our TOLL-FREE customer service number.* Our Customer Service Agents will provide immediate assistance to you.

Toll-Free Customer Service Number

1-800-999-8899

Mon. - Fri. 9 a.m. - 5 p.m. PST

www.marcypro.com

support@impex-fitness.com

IMPORTANT SAFETY NOTICE

PRECAUTIONS

This exercise machine is built for optimum safety. However, certain precautions apply whenever you operate a piece of exercise equipment. Be sure to read the entire manual before you assemble or operate your machine. In particular, note the following safety precautions:

1. **Keep children and pets away from the machine at all times. DO NOT leave children unattended in the same room with the machine.**
2. Only one person at a time should use the machine.
3. If the user experiences dizziness, nausea, chest pain, or any other abnormal symptoms, STOP the workout at once. CONSULT A PHYSICIAN IMMEDIATELY.
4. Position the machine on a clear, leveled surface. DO NOT use the machine near water or outdoors.
5. Keep hands away from all moving parts.
6. Always wear appropriate workout clothing when exercising. DO NOT wear robes or other clothing that could become caught in the machine. Running or aerobic shoes are also required when using the machine.
7. Use the machine only for its intended use as described in this manual. DO NOT use attachments not recommended by the manufacturer.
8. Do not place any sharp object around the machine.
9. Disabled person should not use the machine without a qualified person or physician in attendance.
10. Before using the machine to exercise, always do stretching exercises to properly warm up.
11. Never operate the machine if the machine is not functioning properly.
12. A spotter is recommended during exercise.

CARE AND MAINTENANCE

1. Inspect and tighten all parts before using the machine.
2. The machine can be cleaned using a damp cloth and mild non-abrasive detergent. DO NOT use solvents.
3. Maximum weight capacity 300 lbs. on the uprights.
4. Maximum weight capacity 100 lbs. on the butterflies.
5. Maximum weight capacity 100 lbs. on the leg developer.
6. Maximum weight capacity 100 lbs. on the arm curl.
7. Maximum user's weight: 300 lbs.

WARNING: BEFORE BEGINNING ANY EXERCISE PROGRAM, CONSULT YOUR PHYSICIAN. THIS IS ESPECIALLY IMPORTANT FOR INDIVIDUALS OVER THE AGE OF 35 OR PERSONS WITH PRE-EXISTING HEALTH PROBLEMS. READ ALL INSTRUCTIONS BEFORE USING ANY FITNESS EQUIPMENT. IMPEX INC. ASSUMES NO RESPONSIBILITY FOR PERSONAL INJURY OR PROPERTY DAMAGE SUSTAINED BY OR THROUGH THE USE OF THIS PRODUCT.

SAVE THESE INSTRUCTIONS.

WARNING LABEL PLACEMENT

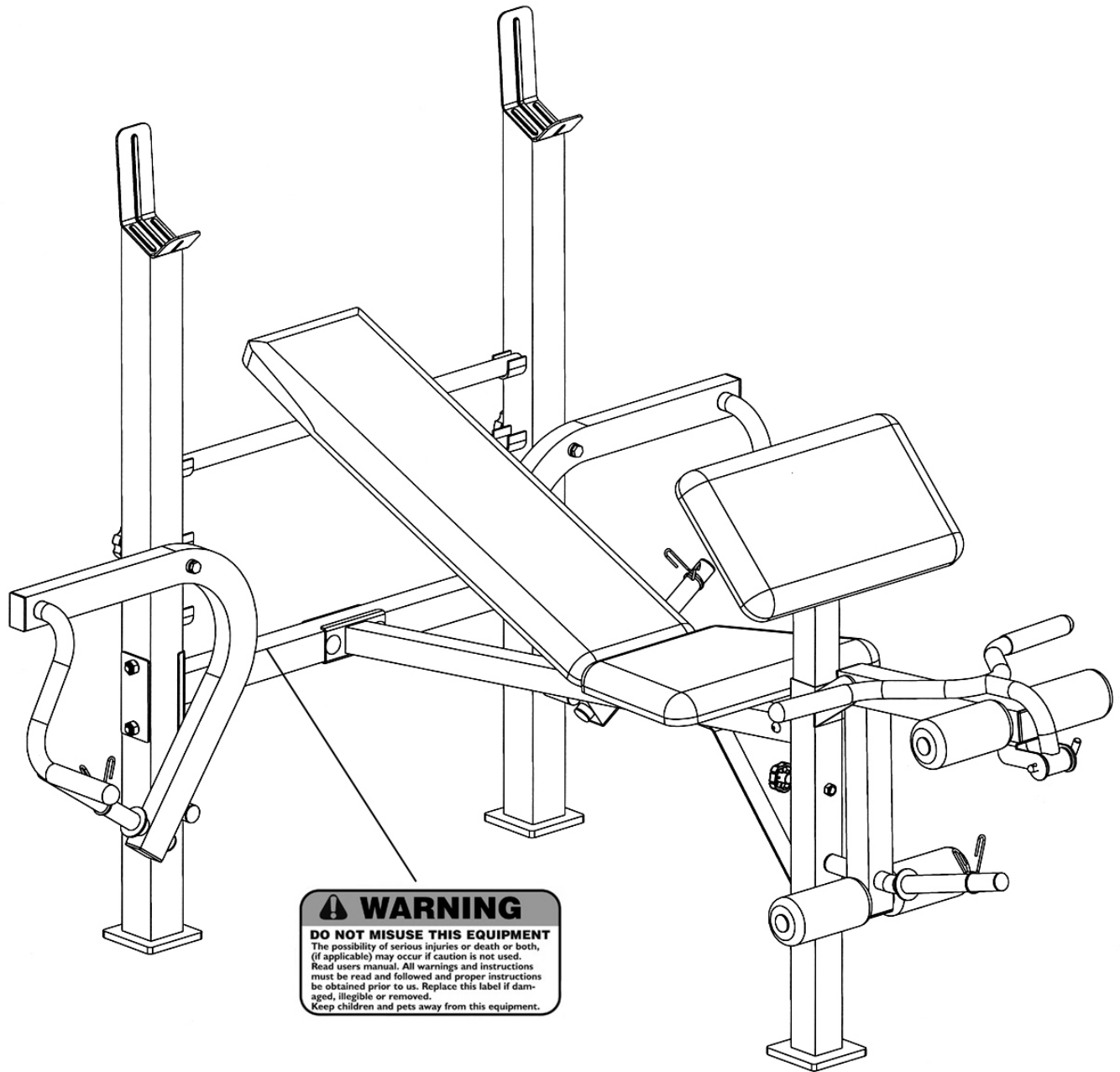

The Warning Label shown here has been placed on the Cross Brace. If the label is missing or illegible, please call customer service at 1-800-999-8899 for replacement. Apply the label in location shown.

HARDWARE PACK

NOTE: The following parts are not drawn to scale. Please use your own ruler to measure the size.

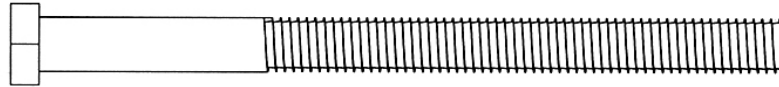

#41 M10 x 5 $\frac{1}{8}$ " Hex Bolt (Qty 2)

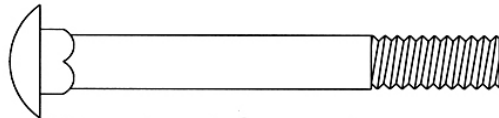

#34 M10 x 3 $\frac{1}{8}$ " Carriage Bolt (Qty 4)

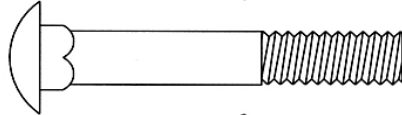

#35 M10 x 2 $\frac{1}{2}$ " Carriage Bolt (Qty 2)

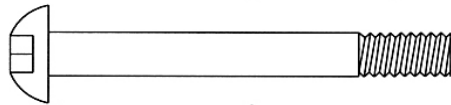

#36 M10 x 2 $\frac{3}{4}$ " Allen Bolt (Qty 1)

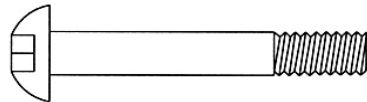

#38 M8 x 2 $\frac{1}{8}$ " Allen Bolt (Qty 1)



#39 M6 x 1 $\frac{1}{2}$ " Hex Bolt (Qty 4)



#40 M6 x 1 $\frac{3}{8}$ " Hex Bolt (Qty 4)

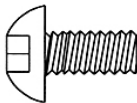

#37 M8 x $\frac{5}{8}$ " Allen Bolt (Qty 6)

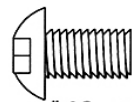

#42 M10 x $\frac{5}{8}$ " Allen Bolt (Qty 2)



#43 \varnothing $\frac{1}{2}$ " Washer (Qty 8)



#44 \varnothing $\frac{5}{8}$ " Washer (Qty 8)



#45 \varnothing $\frac{3}{4}$ " Washer (Qty 8)

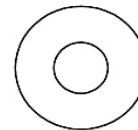

#46 \varnothing $\frac{3}{4}$ " Large Washer (Qty 2)



#47 M10 Aircraft Nut (Qty 7)



#48 M8 Aircraft Nut (Qty 1)



#49 Long Hex Nut (Qty 2)

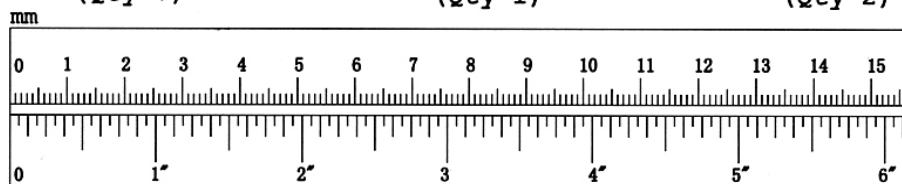

ASSEMBLY INSTRUCTION

Tools Required for Assembling the Machine: Two Adjustable Wrenches and Allen Wrenches. NOTE: It is strongly recommended that two or more people assemble this machine to avoid possible injury.

STEP 1 (See Diagram 1)

- A.) **Do not tighten Nuts and Bolts until instructed to do so.**
- B.) Connect the Right & Left Upright Beams (#1 & 2) by a Cross Brace (#4) in the mid-span. Align the holes and secure each end of the Cross Brace with one 4 3/4" x 3 1/2" Bracket (#13), two M10 x 3 1/8" Carriage Bolts (#34), two Ø 3/4" Washers (#45), and two M10 Aircraft Nuts (#47).
- C.) Place Backrest Adjustment Bar (#9) between the two Upright Beams onto selected slots to obtain desired Backrest Incline.

DIAGRAM 1

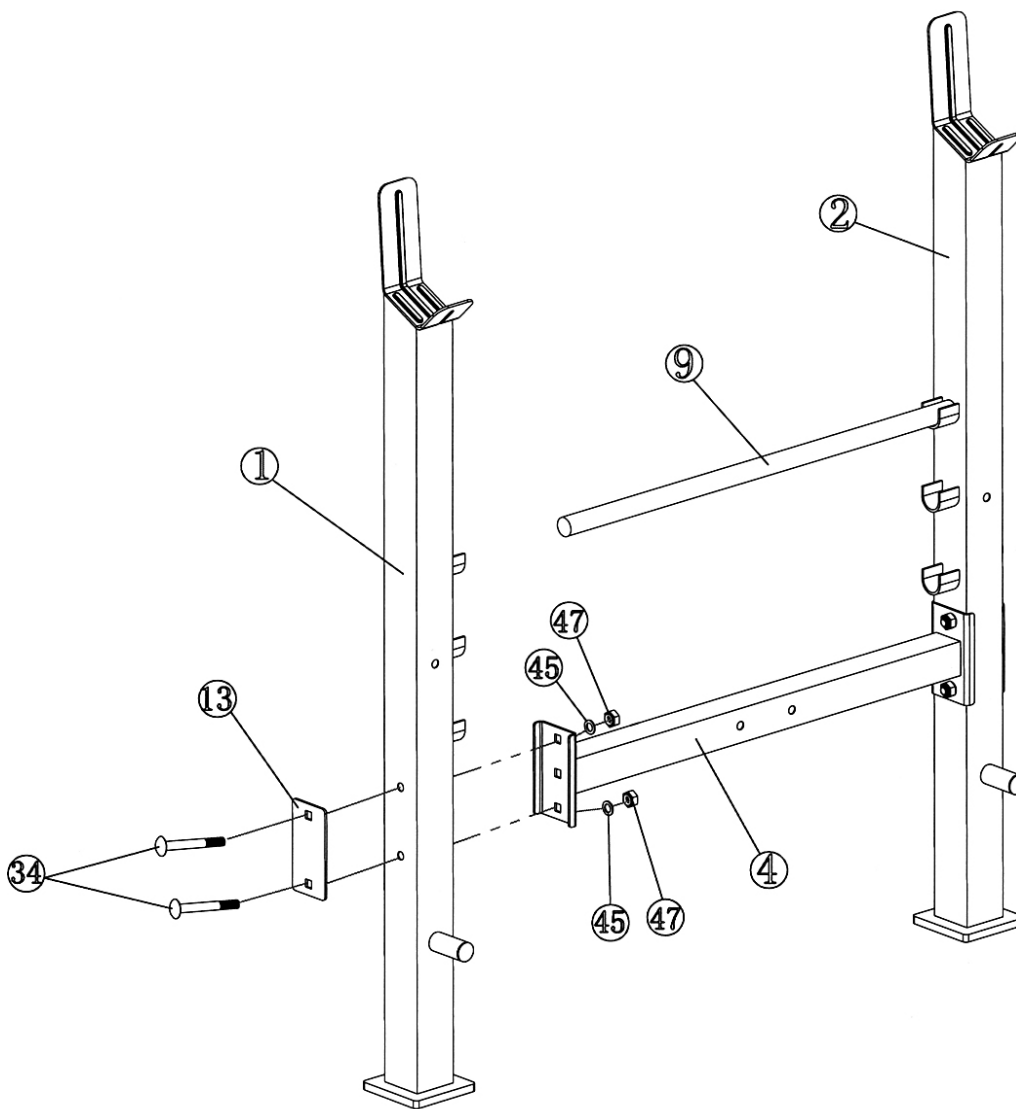

STEP 2 (See Diagram 2)

- A.) **Do not tighten Nuts and Bolts until instructed to do so.**
- B.) Attach Main Seat Support (#3) to the Cross Brace (#4). Secure it with a 4 3/8" x 3 3/8" Bracket (#12), two M10 x 2 1/2" Carriage Bolts (#35), two \varnothing 3/4" Washers (#45), and two M10 Aircraft Nuts (#47).
- C.) Attach the Front Post (#5) to the Main Seat Support. Secure it with three M8 x 5/8" Allen Bolts (#37) and three \varnothing 5/8" Washers (#44). Thread the M10 x 2 3/8" Lock Knob (#31) into the Front Post.
- D.) Attach the Diagonal Support (#8) to Main Seat Support. Secure it with one M8 x 2 1/8" Allen Bolt (#38), two \varnothing 5/8" Washers (#44), and one M8 Aircraft Nut (#48).
- E.) Attach the other end of Diagonal Support to Front Post. Secure it with one M8 x 5/8" Allen Bolt (#37) and one \varnothing 5/8" washer (#44).
- F.) Insert a M10 x 5 1/8" Hex Bolt (#41) through the hole on a Butterfly (#15). Secure the Bolt with a Long Hex Nut (#49). Insert the Bolt through the hole on the Right Upright Beam (#1) and secure with a M10 Lock Knob (#32). Repeat the same step to install the other Butterfly to Left Upright Beam (#2),
- G.) **Securely tighten all Nuts and Bolts installed in Step-1 and Step-2.**

DIAGRAM 2

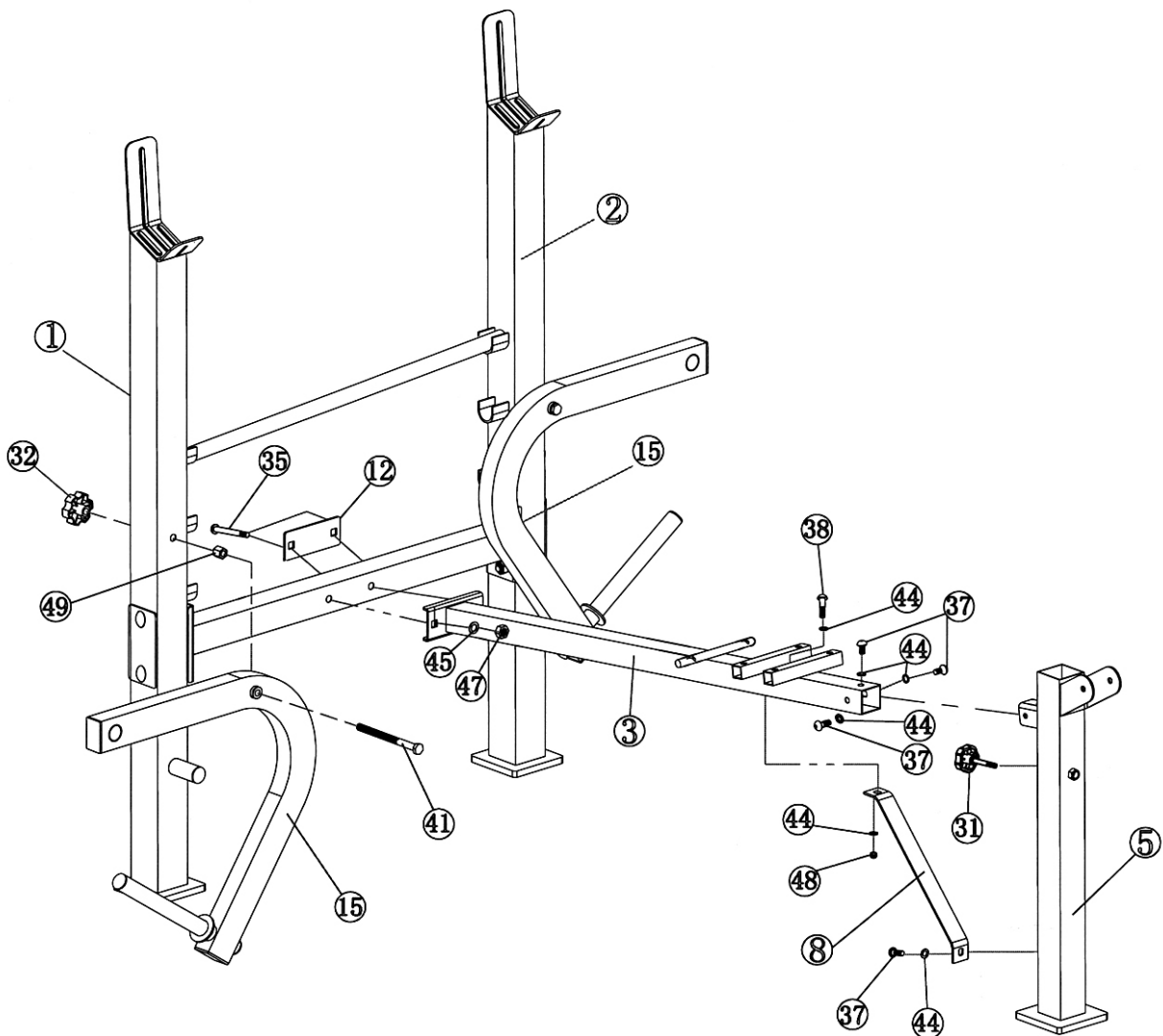

STEP 3 (See Diagram 3)

- A.) Attach the Leg Developer (#7) to the Front Post (#5). Secure it with one M10 x 2 3/4" Allen Bolt (#36), two Ø 3/4" Washers (#45), and one M10 Aircraft Nut (#47).
- B.) Attach the Arm Curl Handle (#14) to the open bracket on Leg Developer. Secure it with a L-shaped Lock Pin (#26).
- C.) Attach the Butterfly Handle (#16) to right Butterfly (#15). Secure it with one M10 x 5/8" Allen Bolt (#42) and one Ø 3/4" Large Washer (#46). Repeat same step to install the other Butterfly Handle to the left Butterfly.
- D.) **Do not over tighten Nut and Bolts. Make sure the Leg Developer and Butterfly can swivel freely.**

DIAGRAM 3

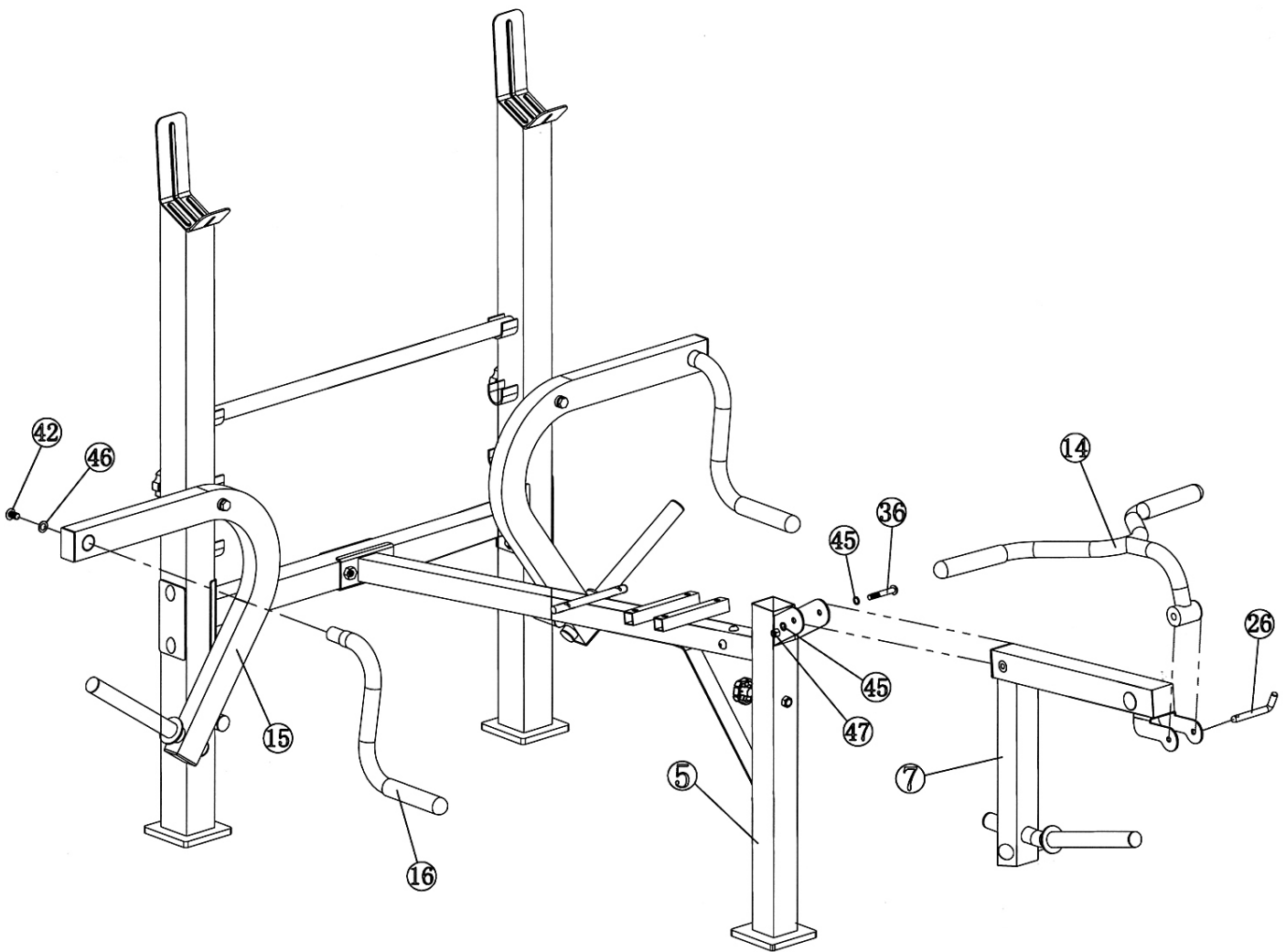

STEP 4 (See Diagram 4)

- A.) Attach the two side-holes on the two Backrest Supports (#10) to the pivot on the Main Seat Support (#3). Place the other end of Backrest Supports against the Backrest Adjustment Bar (#9)
- B.) Place the Backrest Board (#17) onto the Backrest Supports. Secure it with four M6 x 1 1/2" Hex Bolts (#39) and four Ø 1/2" Washers (#43).
- C.) Attach the Seat (#18) to the Main Seat Support (#6). Secure it with four M6 x 1 3/8" Allen Bolts (#40) and four Ø 1/2" Washers (#43).
- D.) Attach the Arm Curl Pad (#19) to the Arm Curl Stand (#6). Secure it with two M8 x 5/8" Allen Bolts (#37) and two Ø 5/8" Washers (#44).
- E.) Insert the Arm Curl Stand into the opening on Front Post (#5). Use the M10 x 2 3/8" Lock Knob (#31) to lock it in position.

DIAGRAM 4

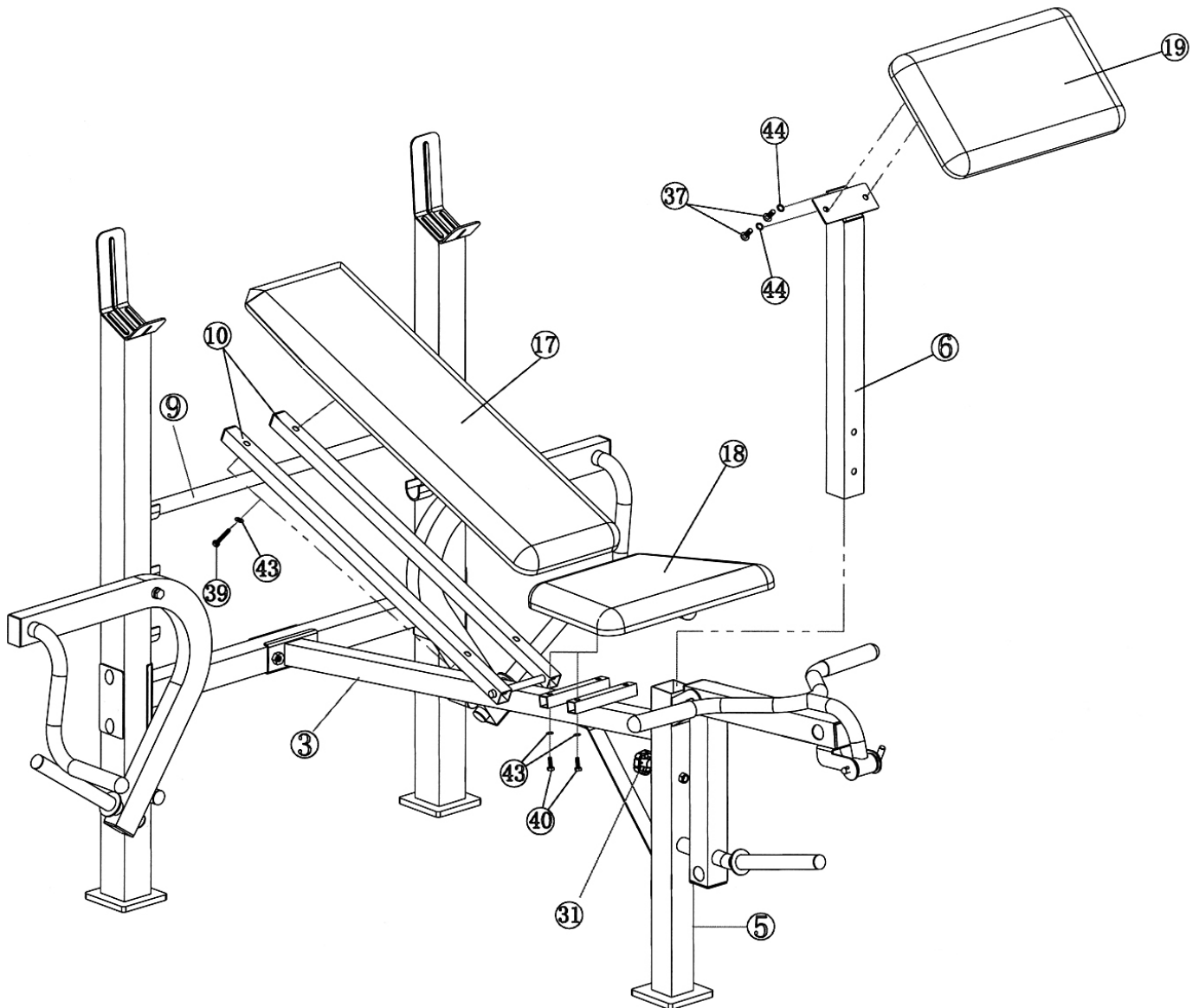

STEP 5 (See Diagram5)

- A.) Insert two Foam Tubes (#11) halfway through the holes on Leg Developer (#7). Push four Foam Rolls (#20) onto the Tubes from both ends.
- B.) Attach a Spring Clip (#21) to the weight post on Leg Developer and Butterfly.

DIAGRAM 5

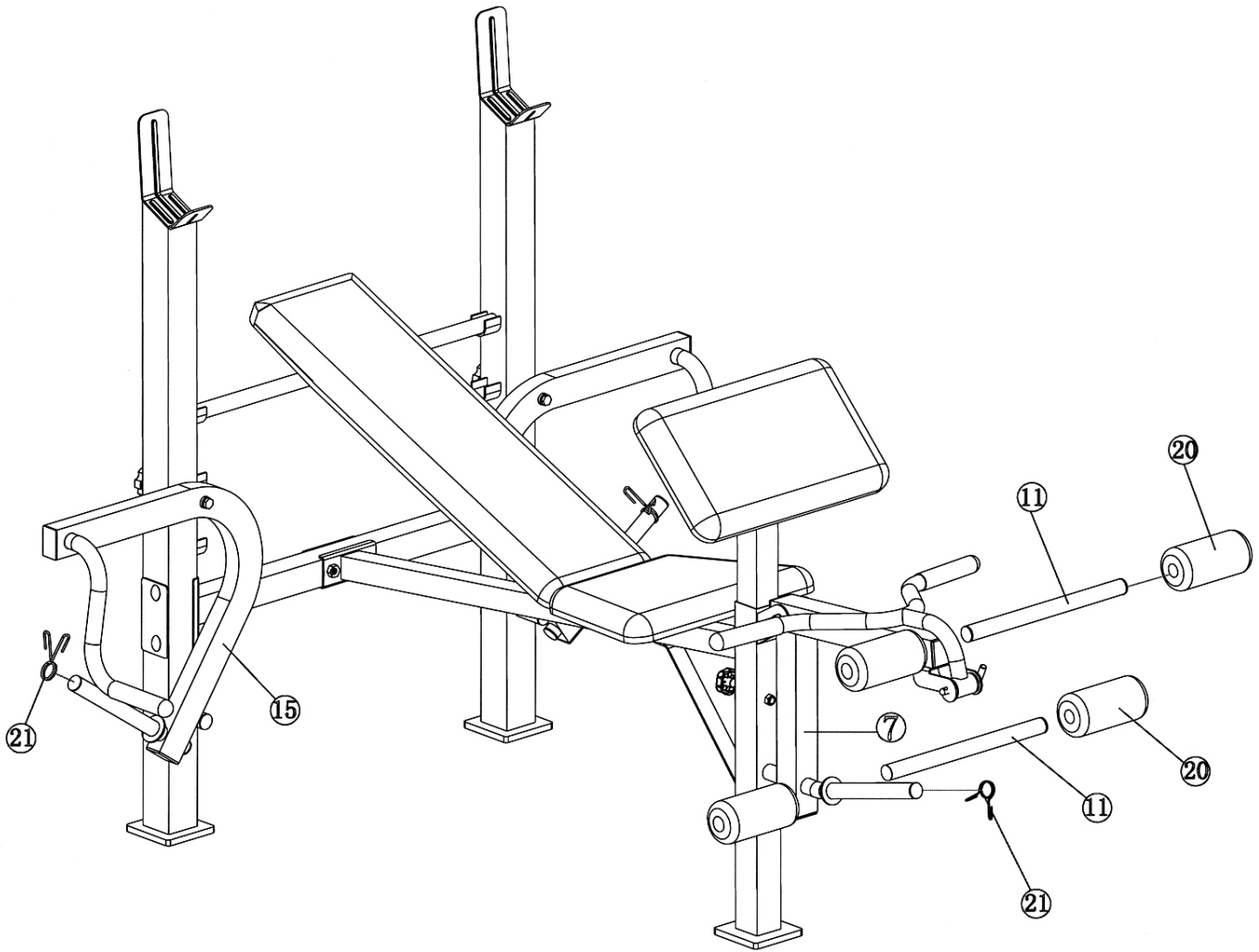

EXPLODED DIAGRAM

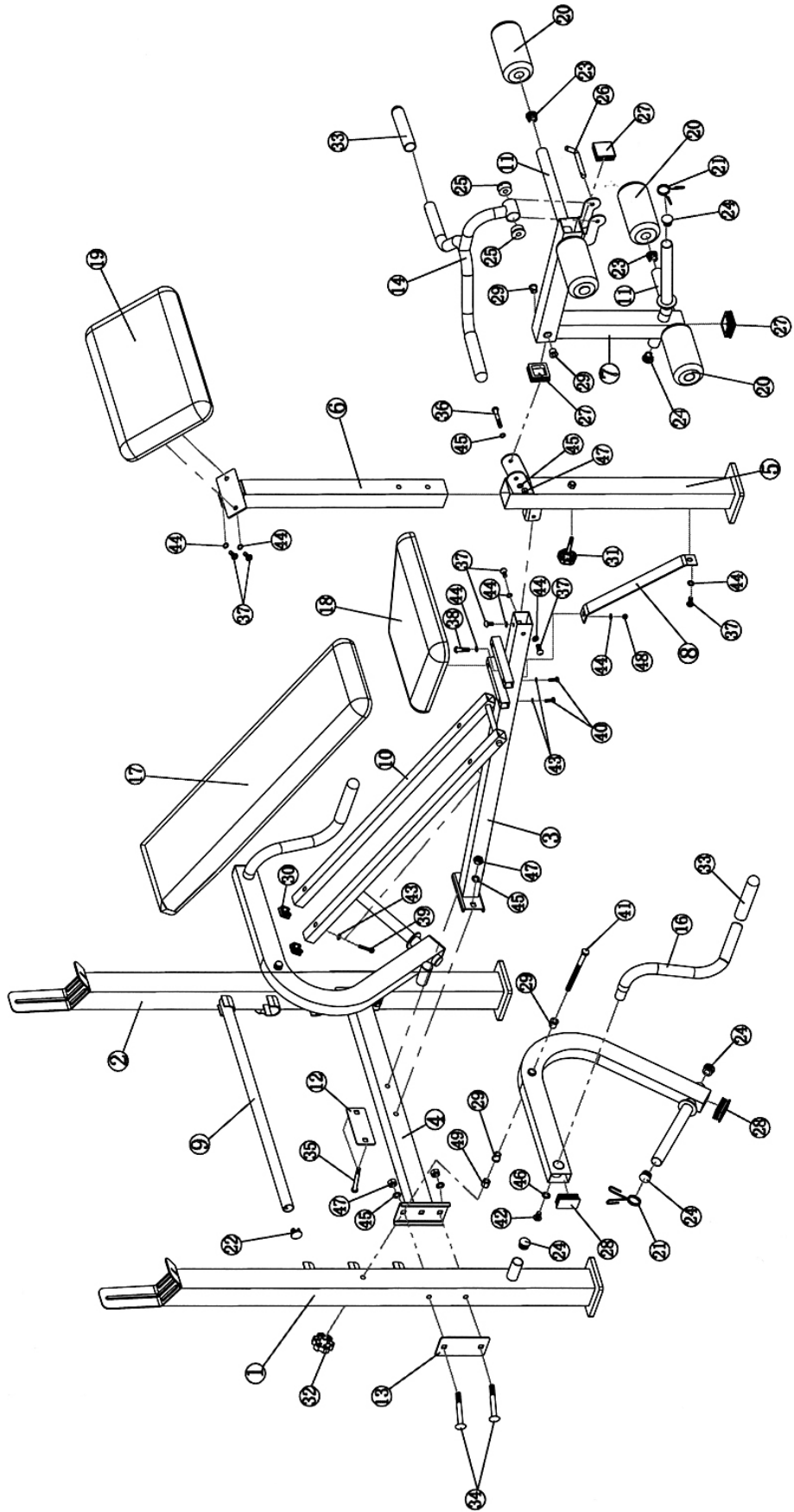

PARTS LIST

KEY NO.	DESCRIPTION	Q'ty
1	Right Upright Beam	1
2	Left Upright Beam	1
3	Main Seat Support	1
4	Cross Brace	1
5	Front Post	1
6	Arm Curl Stand	1
7	Leg Developer	1
8	Diagonal Support	1
9	Backrest Adjustment Bar	1
10	Backrest Support	2
11	Foam Tube	2
12	4 3/8" x 3 3/8" Bracket	1
13	4 3/4" x 3 1/2" Bracket	2
14	Arm Curl Handle	1
15	Butterfly	2
16	Butterfly Handle	2
17	Backrest Board	1
18	Seat Pad	1
19	Arm Curl Pad	1
20	Foam Roll	4
21	Spring Clip	3
22	Ø 1" Backrest Adjustment End Cap	2
23	Ø 1" Foam Tube End Cap	4
24	Ø 1" End Cap	8
25	Ø 1 1/4" Bushing	2
26	L-shaped Lock Pin	1
27	1 3/4" Square End Cap	3
28	1 1/8" x 2" End Cap	4
29	Ø 3/4" Bushing	6
30	1" Square End Cap	2
31	M10 x 2 3/8" Lock Knob	1
32	M10 Lock Knob	2
33	Handle Grip	4
34	M10 x 3 1/8" Carriage Bolt	4
35	M10 x 2 1/2" Carriage Bolt	2
36	M10 x 2 3/4" Allen Bolt	1
37	M8 x 5/8" Allen Bolt	6
38	M8 x 2 1/8" Allen Bolt	1
39	M6 x 1 1/2" Hex Bolt	4
40	M6 x 1 3/8" Hex Bolt	4
41	M10 x 5 1/8" Hex Bolt	2
42	M10 x 5/8" Allen Bolt	2
43	Ø 1/2" Washer	8
44	Ø 5/8" Washer	8
45	Ø 3/4" Washer	8
46	Ø 3/4" Large Washer	2
47	M10 Aircraft Nut	7
48	M8 Aircraft Nut	1
49	Long Hex Nut	2

IMPEX[®] INC.

LIMITED WARRANTY

IMPEX Inc. ("IMPEX[®]") warrants this product to be free from defects in workmanship and material, under normal use and service conditions, for a period of two years on the Frame from the date of purchase. This warranty extends only to the original purchaser. IMPEX's obligation under this Warranty is limited to replacing or repairing, at IMPEX's option.

All returns must be pre-authorized by IMPEX. Pre-authorization may be obtained by calling IMPEX Customer Service Department at 1-800-999-8899. All freights on products returned to IMPEX must be prepaid by the customer. This warranty does not extend to any product or damage to a product caused by or attributable to freight damage, abuse, misuse, improper or abnormal usage or repairs. No other warranty beyond that specifically set forth above is authorized by IMPEX.

IMPEX is not responsible or liable for indirect, special or consequential damages arising out of or in connection with the use or performance of the product or other damages with respect to any economic loss, loss of property, loss of revenues or profits, loss of enjoyments or use, costs of removal, installation or other consequential damages or whatsoever natures. Some states do not allow the exclusion or limitation of incidental or consequential damages. Accordingly, the above limitation may not apply to you.

The warranty extended hereunder is in lieu of any and all other warranties and any implied warranties of merchantability or fitness for a particular purpose is limited in its scope and duration to the terms set forth herein. Some states do not allow limitations on how long an implied warranty lasts. Accordingly, the above limitation may not apply to you.

This warranty gives you specific legal right. You may also have other rights which vary from state to state. Register on-line at www.marcypro.com

IMPEX[®] INC.
2801 S. Towne Ave.
Pomona, CA 91766

ORDERING REPLACEMENT PARTS

Replacement parts can be ordered by calling our Customer Service Department toll-free at **1-800-999-8899** during our regular business hours: Monday through Friday, 9 am until 5 pm Pacific standard time.

support@impex-fitness.com

When ordering replacement parts, always give the following information.

1. Model
2. Description of Parts
3. Part Number
4. Date of Purchase